

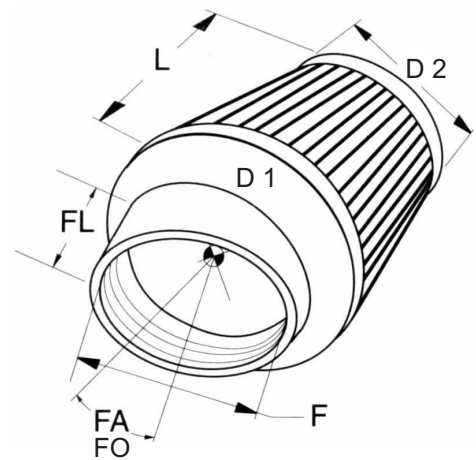

**Noch mehr Luftdurchsatz!  
Nur für den Renneinsatz!**

F	D1	D2	L	FL	FA	
62	102		121	19	C	RX- 4040-1
62	114	102	155	76	20°	RX- 3800
62	114	152	155	76	20°	RX- 3770
63	114	102	97	19	C	RX- 4010
63	152	127	140	51	C	RX- 4950
63	152	127	165	51	C	RX- 4860
70	152	127	140	51	C	RX- 4960
70	152	127	165	51	C	RX- 4870
73	108	102	121	24	C	RX- 4020-1
76	114	152	117	22	C	RX- 3900-1
76	140	127	141	48	C	RX- 4990
76	140	127	165	48	C	RX- 4730
76	152	102	220	24	C	RX- 3990-1
76	152x203	127	165	48	C	RX- 4750
84	124	102	108	24	C	RX- 4120-1
89	102		146	19	C	RX- 4140
97	173	173	54	19	C	RX- 4130-1



- F Flansch Durchmesser
- D 1 Filter Basis Durchmesser
- D 2 Filter Kappe Durchmesser
- L Filter Länge
- FL Flansch Länge
- FA Flansch Winkel in °
- FO Flansch Offset
- C = Mitte

V-20033 RX-5090

**Reverse Style**  
maximaler  
Luftdurchsatz

